

e-Electro-Mechanical

Control System Troubleshooting

Workshop



Clarence Richard Company
3908 Tonkawood Road
Minnetonka, MN 55345
952/939-6000

www.clarencrichard.com/e-electromech/



for Electricians, Mechanics and Maintenance

100% of the On-Line Participants surveyed testified they would recommend this course (5-2-2011).

- **On-Line** on the internet
- **On-Demand** when you want
- **Self-Paced** at the rate you want
- **At Your Place** on your computer
- **Convenient** when you want to pause training
- **Review** before testing
- **Testing**; know which ones are wrong and why

From the company providing industrial training for over 15 years; Clarence Richard Company now provides it's proven classroom training method within easy reach in a very effective, On-Line, interactive, engaging means of quickly and easily training Participants to troubleshoot and maintain very complex systems.

Sometimes your people cannot be trained at a specific time because of other commitments. Or they register for a class and find they can't be there for unforeseen reasons. Or the time and expense becomes too great to travel. Or you're left wondering what your people really experienced and retained from the training.

Your people may pick and choose when they want to learn and where they want to learn it. Considering the alternative Traditional Classroom Method, we make it a snap. Participants can be tested for what they know and retained.

The benefits from traditional have not changed; we've just added more impact. What can you possibly find as a better payback than teaching your people to safely troubleshoot control systems. Our Workshop has stood the test of time and has been around for a decade and a half. Our customers keep coming back. We are just making it so you do not have to trek so far and you can train on your schedule. The fee is nominal the benefits are great. Come see how high the bar has been raised to.

Take the virtual classroom tour of our on-line e-ElectroMechanical Systems Maintenance Workshop at www.clarencrichard.com/e-electromechechtour/ . The tour is an actual Workshop sample that includes all the navigation instructions, and several slides from each module illustrating the narration, graphics, animation, videos.

Clarence Richard Company offers their seminar tailored to significantly improving the skill level. Operators will learn about Electrical Safety and Basic Electricity including troubleshooting procedures and test meter usage. This will be accomplished by focusing instruction on the troubleshooting process and the latest in state-of-the-art procedures. This successful workshop has been given the highest marks by past attendees.

1 Basic Electricity

Understanding electricity has not been made so easy is a common remark that has been made over the 15 years this Workshop has been performed. We approach this module as if the participant has no idea how electricity works. Many claim they only know enough to stay away from it. If you repeat these next six modules enough times, you will have a good foundation to work from. You will be able to pass along observations to plant controls people over the phone, trouble shoot and make some if not most repairs or all repairs yourself while working on equipment safely.

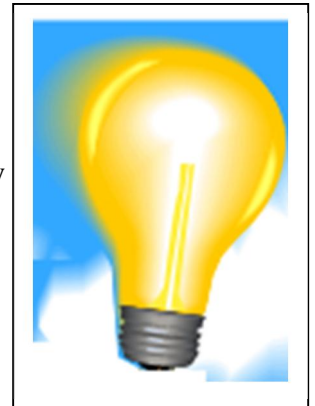

This module is important for the person with no formal training and experienced Journeyman Electrician as well. Fundamental Concepts are introduced that are stepping stones that are required knowledge necessary to map out the strategies used to efficiently troubleshoot the challenges presented in the consequential modules.

□ 2 Circuit Analysis

What measurements should we measure in a good working circuit? Once we know that, a circuit not working is again measured and then analyzed on the different measurements between a good working circuit and a bad circuit. Directions are determined where to measure next until we make the determination of the fault. This may seem easy. Participants normally need coaxing to measure the circuit under the condition it failed. Participants are tested during and at the end of each module and are encouraged to repeat the module as many times to make one most proficient.

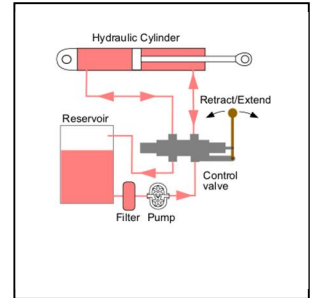

□ 3 Safe Meter Usage

The meters measure resistance, voltage and amperage. Depending on the circumstances, one needs to set these up properly to safely read the value being measured. Some meters are auto ranging while other meters need to be ranged. Know when your meter is reading correctly and when it is not.



At this juncture, we are not only talking about how electricity works but asking the Participant to measure something that has the potential to release an extreme amount of energy in the form of heat and current flow. The Participant is trained to protect themselves against electrocution and Arc Flash.

□ 4 Troubleshoot – Beginner

Every plant has many high voltage motors and motor starters that require troubleshooting, maintenance and repair. It's important the job is done right and safely. OSHA requires circuits to be measured for no voltage when a disconnect is used to isolate the voltage from employees.

If your people are in motor control cabinets and rewire motors, this alone is reason enough to be taking this module.

This module discusses in depth the motor and motor control circuitry. Problems in the circuit and their related operational symptoms are discussed. Symptoms of circuit problems are analyzed and the best checks are made using this information.



□ 5 Troubleshoot – Advance

Electrical controls is more than supplying 480 vac or 120 vac to lights, motors and coils, etc. Equipment is also controlled from the varying AC and DC signals from load cells, VFDs, DC Motor controls, tachometers, potentiometers, etc. These circuits are explained and problems introduced into the circuits and then the Symptoms Game starts. This game is very effective in getting our point across and the challenge makes it fun for all.

A control system is normally made up electrical components and many times used in conjunction with mechanical devices. Sometime the control system is fixed with a wrench instead of an electrical test meter. Understanding the entire system and how it works is necessary to determine the root of the problem.

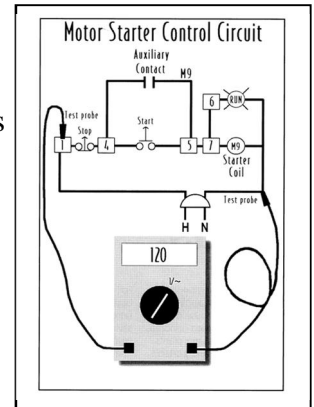

□ 6 Troubleshoot – Expert

A closed loop control system is studied, then analyzed for the resulting symptoms once the system has been given a problem. This Module requires all the knowledge and skill gained from the previous Electrical Modules plus. The problem may not be an electrical one or a mechanical one but parameters programmed on a VFD or Blending control or a Continuous Weigh Scale. The problem may be intermittent or continuous. The problem may be in the control house or at the equipment location or in the motor control room or the cable in between.

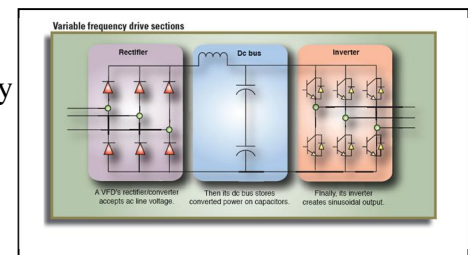

A complex machine made up of the components previously studied is this module's case study. This machine is a component of a larger machine. Once this machine is understood, the fundamentals learned in this all the previous modules relate to most all other electro-mechanical machines, procedures and processes.]